

# TGC Construction Review

**Issue Date:** Jul 4, 2014      **Location:** 500 Figueros St.  
**Prepared By:** Steven Evans      **Project Name:** TGC Headquarters  
**Project Number:** 14.016      **Project Type:** Office  
**Subject:** Punchlist









## Contacts

Company	Name	Initials	Email Address	Phone Number
3a Architects	Steven Evans	SE	sevans@3a.com	555.434.5090
Hamilton Construction Co.	Barbara Hamilton	BH	bhamilton@hamiltonCCO.com	555.500.3990
Flemming Interiors	Jacob Goodspeed	JG	jgoodspeed@fint.com	555.988.9800
Pacific Mechanical Engineers	Jeff Hall	JH	jhall@PacMechEng.com	555.600.9000
West Coast Fire	Daniel Weiss	DW	dweiss@wcf.com	555.988.1122
SUP Structural Engineers	Angela Reeve	AR	reeve@SUP.com	555.770.4400
Volt Electrical	Jackie North	JN	jnorth@voltE.com	555.223.8888
CAP Financial	Adam Fischer	AF	adam@CAP.com	555.222.5450

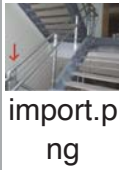
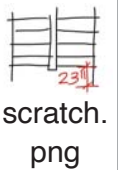
Distribution: SE, BH, JG, JH, DW, AR, JN, AF

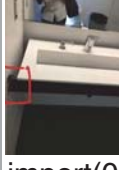

# TGC Construction Review

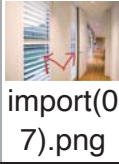

#	Dev / Code	Location	Scope	Item	Description	Image 1	Image 2	Status	Date Entered	Deadline Date	Age In Days	Cited By	Action By	Spec Section	Priority	Pin	Video	Audio
1	YES	Stair 2 Level 9 Landing	AA	DN	The handrail extension to not meet the required length. See sheet A7.01 for dimensions and A0.55 for Accessibility standards. Correct handrail extension as designed.	 import.png	 scratch.png	Open	Jun 4, 2014	Sep 4, 2014	52	SE	BH	102616.16	High	1014_TG H_Rev4.pdf	YES	NO
2		Conference Room 2-34	AA	CN	Repair tile to carpet transition.	 import(00).png		Open	Jul 4, 2014	Aug 4, 2014	22	JG	BH	096519	Med		NO	NO
3		Loading Dock Entry. Room 1-66	HA	CN	Replace Corner guard. Protect from construction related damage.	 import(01).png		Open	Jul 4, 2014	Aug 4, 2014	22	JG	BH	102613	Low	1014_TG H_Rev4.pdf	NO	YES
4	YES		AA	DN	Provide plumbing heat protective cover. See A0.51 for Accessibility standards.	 import(02).png		Open	Jul 4, 2014	Aug 4, 2014	22	SE	BH	055819	High		YES	NO
5		Level 04 Men's. Room 4-05	AH	RFC	Inspector noted the need for cover over vanity support. Cover not included in drawings. Provide information	 import(03).png		Open	May 4, 2014	Jul 3, 2014	83	BH	SE		Low		NO	NO
6		Level 10 - Executive Shower. Room 9-30	PL	ACO	See RFI 23 and CO 4. Approved changed order for rain type shower head by Kohler. Remove and replace.	 import(06).png	 scratch(01).png	Closed	Jul 4, 2014	Aug 5, 2014	22	DW	BH	224000	Low		YES	NO
7			SD		LEED checklist calls out mecho shade type shades with a minimum of 15% openness. Remove and replace window shades per LEED checklist.	 import(07).png		Open	Jul 4, 2014	Aug 7, 2014	22	SE	BH	122400	Med		NO	YES

# TGC Construction Review

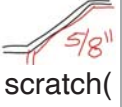

#	Dev / Code	Location	Scope	Item	Description	Image 1	Image 2	Status	Date Entered	Deadline Date	Age In Days	Cited By	Action By	Spec Section	Priority	Pin	Video	Audio
8	YES		ID	IR	Inspector requested stair stringer calculations. Architect to request calculations from Stair manuf.	 import(09).png		Open	Jun 4, 2014	Jul 4, 2014	52	BH	SE	096956	Med	1014_TG H_Rev4.pdf	YES	NO
9	YES	Penthouse Stair - Room 11-03	FP	CN	Provide 1 layer of 5/8" type X gyp underside stair throughout per Detail 6/A5.11.	 import(10).png	 scratch(00).png	Open	Jul 4, 2014	Aug 4, 2014	22	SE	BH	035116	High	1014_TG H_Rev4.pdf	NO	NO



## Referenced Images



import.png



import(00).png



import(01).png



import(02).png



import(03).png



import(06).png

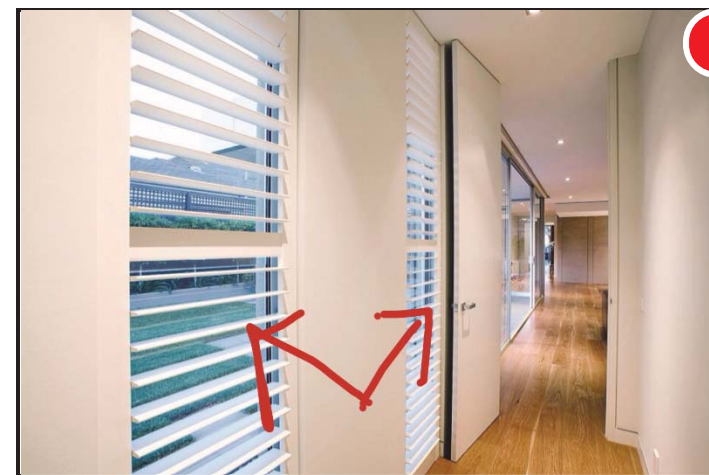

import(07).png

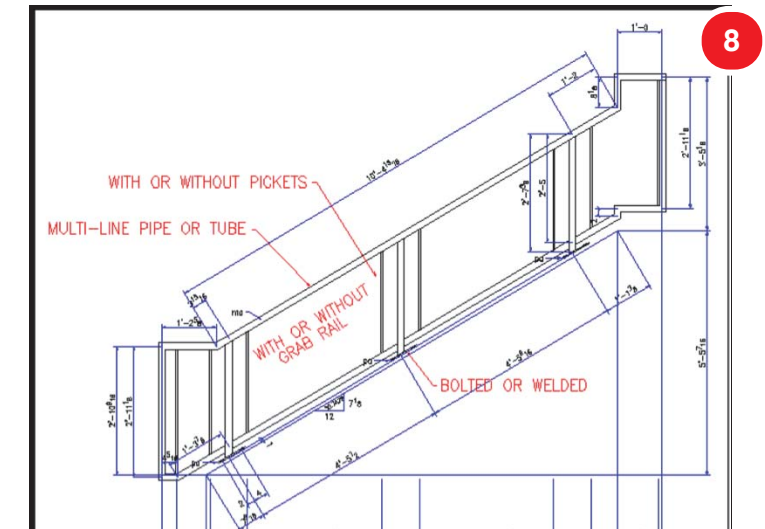

import(09).png

# TGC Construction Review



import(10).png

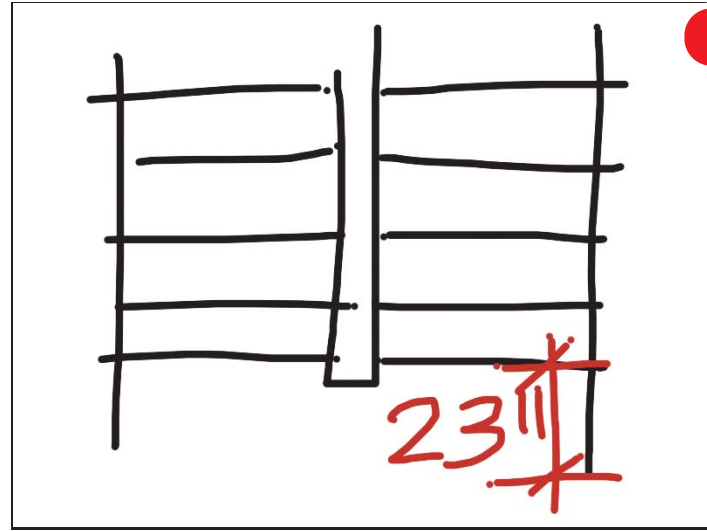

scratch.png

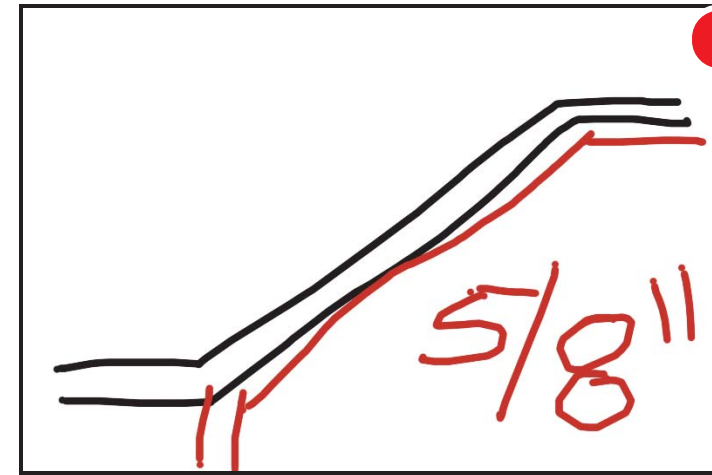

scratch(00).png

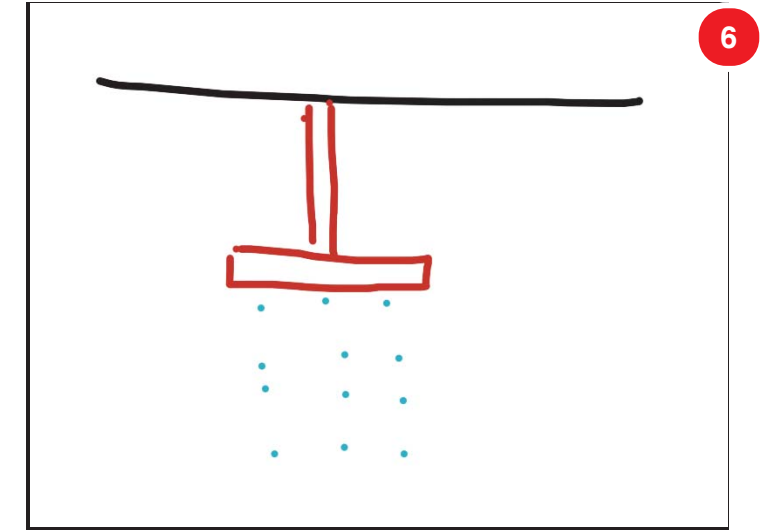

scratch(01).png



## Referenced PDF Files

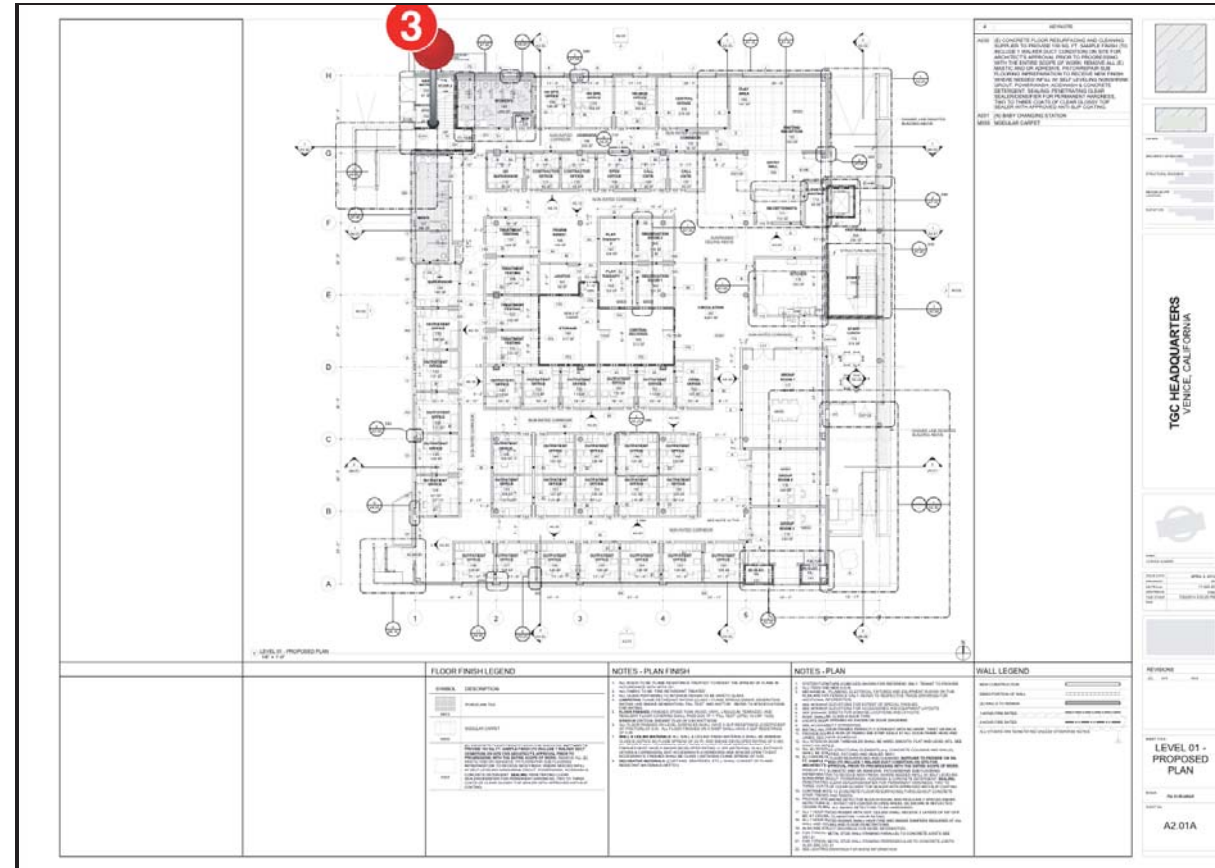

1014\_TGH\_Rev4.pdf

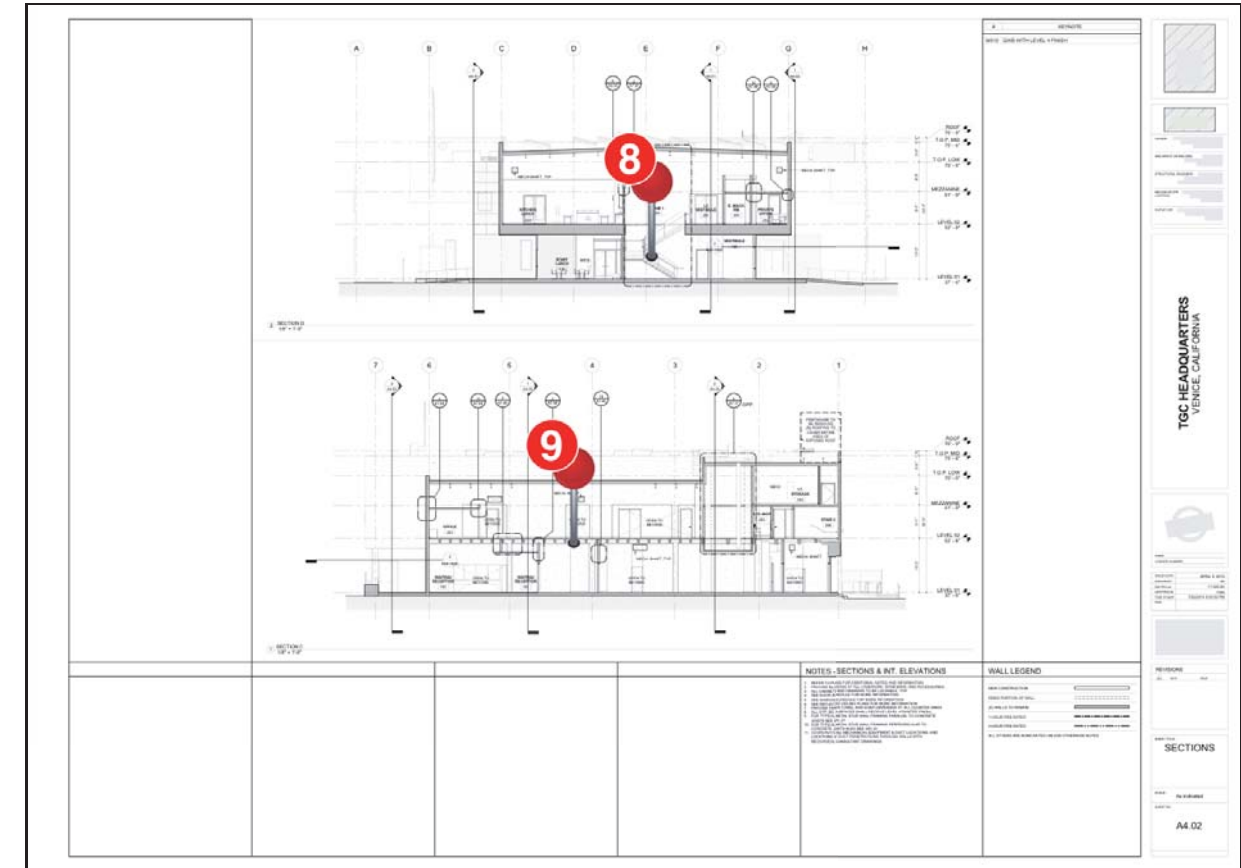

1014\_TGH\_Rev4.pdf

# TGC Construction Review

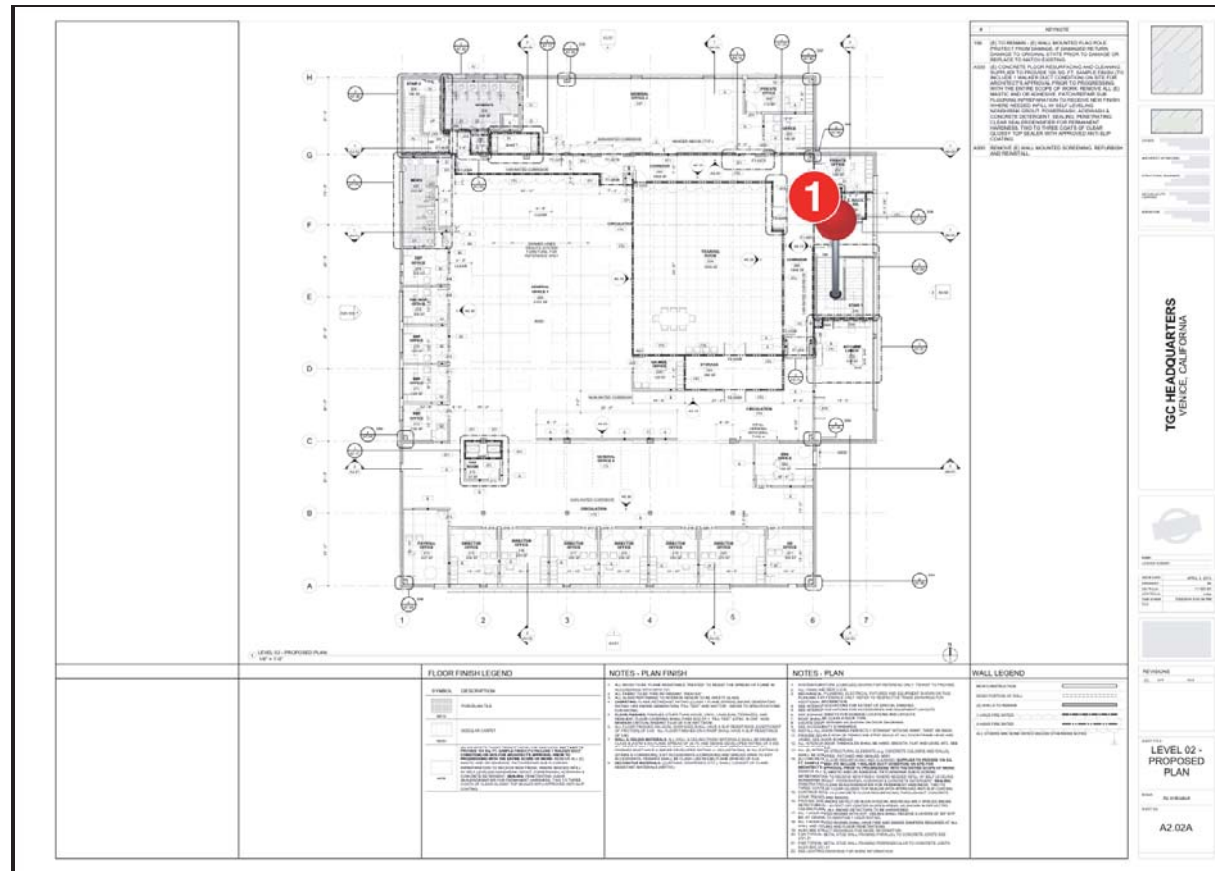

1014\_TGH\_Rev4.pdf



## SCOPE ABBREV & DESCRIPTION

AA	Accessibility ADA	3
AH	Architectural	1
FP	Fire Protection	1
HA	Hardware	1
ID	Interior Design	1
PL	Plumbing	1
SD	Sustainable Design	1

## ITEM CODE ABBREV & DESCRIPTION

ACO	Approved Change Order	1
CN	Corrective Notice	3
DN	Deviation Notice	2
IR	Inspection Request	1
RFC	Request for Clarification	1

## SPECIFICATIONS

035000	Cast Decks and Underlayment	1
055000	Metal Fabrications	1
096000	Flooring	2
102000	Interior Specialties	2
122000	Window Treatments	1
224000	Plumbing Fixtures	1